



## About This Manual

This manual contains all of the information you will need to know about your PaceMaster treadmill. Please read this manual in its entirety before attempting to use your treadmill.

For your safety and the protection of your treadmill we have included warnings and other valuable information throughout this manual. This information will be in bold print and marked by the symbols below. Be absolutely sure to thoroughly read and understand this information.

When you see the symbol  CAUTION: be sure to understand and utilize this information. Failure to do so may result in personal injury or damage to your treadmill.

When you see the symbol  you will find useful suggestions related to the section in which it appears.

# PACEMASTER PRO-PLUS™

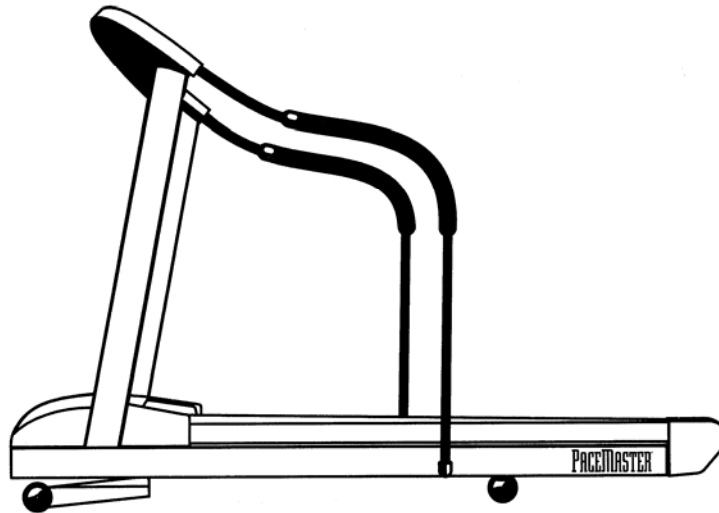

## Table of Contents

About This Manual-----	Front Cover	Using PaceMaster for the First Time-----	10
Important Safety Instructions-----	2	Using the Preprogrammed Courses-----	11
Installation Requirements-----	3	Designing Your Own Courses-----	13
Unpacking our Treadmill-----	4	Maintenance-----	13
Tools for Assembly-----	4	Troubleshooting-----	15
Assembling your PaceMaster-----	4	Specifications-----	15
Understanding the Control Panel-----	7	Workout log-----	16
Exercise and Your Treadmill-----	9		

## OWNERS MANUAL

Congratulations on the purchase of your PaceMaster Treadmill. Not only did you buy one of the highest quality treadmills on the market, you also obtained excellent value for your dollar. Aerobics, Inc. was founded in 1968, and has over 28 years experience in designing and building treadmills. Aerobics, Inc. is a family owned and operated business comprised of physical fitness enthusiasts. Our goal is to provide the consumer with outstanding quality Treadmills at affordable prices.

### **Important Safety Instructions** - Read all instructions before using (this appliance)

Before starting any exercise program, contact your personal physician and have a complete physical. Only your physician can recommend a heart rate training zone that is suitable for you.

When using an electrical appliance, basic precautions should always be followed, including the following:

Read all instructions before using (this appliance).

 **DANGER** - To reduce the risk of electric shock: Always unplug this appliance from the electrical outlet immediately after using and before cleaning.

 **WARNING** - To reduce the risk burns, fire, electrical, or injury to persons:

1. An appliance should never be left unattended when plugged in. Unplug from outlet when not in use, and before putting on or taking off parts
2. Do not operate under blanket or pillow. Excessive heating can occur and cause fire, electrical shock, or injury to persons.
3. Close supervision is necessary when this appliance is used by, on, or near children, invalids, or disabled persons.
4. Use this appliance only for its intended use as described in this manual. Do not use attachments not recommended by the manufacturer
5. Never operate this appliance if it has a damaged cord or plug, if it is not working properly, if it has been dropped or damaged, or dropped into water. Return the appliance to a service center for examination or repair.
6. Do not carry this appliance by supply cord or use cord as a handle.
7. Keep the cord away from heated surfaces.
8. Never operate the appliance with the air openings blocked. Keep the air openings free of lint, hair, and the like.  
Important Safety Instructions continued
9. Never drop or insert any object into any opening.
10. Do not use outdoors.
11. Do not operate where aerosol (spray) products are being used or where oxygen is being administered.
12. To disconnect turn all controls to the off position, then remove plug from outlet.

 **WARNING** - Connect this appliance to a properly grounded outlet only. See grounding instructions below.

### **GROUNDING INSTRUCTIONS**

This product must be grounded. If it should malfunction or breakdown, grounding provides a path of least resistance for electric current to reduce the risk of electric shock. This product is equipped with a cord having an equipment-grounding conductor and a grounding plug. The plug must be plugged into an appropriate outlet that is properly installed and grounded in accordance with all local codes and ordinances.

 **DANGER** - Improper connection of the equipment grounding-conductor can result in a risk of electrical shock. Check with a qualified electrician or serviceman if you are in doubt as to whether the product is properly grounded. Do not modify the plug provided with the product - if it

will not fit the outlet, have a proper outlet installed by a qualified electrician. This product is rated more than 15 amperes and is for use on a circuit having a nominal rating of 120 volts and is factory equipped with a specific electric cord and plug to permit connection to a proper electric circuit. Make sure that the product is connected to an outlet having the same configuration as the plug. No adapter should be used with this product. If the product must be reconnected for use on a different type of electrical circuit, the reconnection should be made by qualified service personal.



**CAUTION** - Read owners manual carefully before operating this equipment. Keep hands and clothing away from belt and rear roller when in motion. Do not allow children or anyone unfamiliar with its operation on or near this treadmill.



**WARNING** - Remove safety key when not in use and store out of reach of children.

- If at any time during your exercise program you find the exercise abnormally difficult, or if you encounter dizziness, feel faint, experience chest pains, feel as though your heart may be skipping beats, or you experience forced heavy breathing after minimum exercise, or you experience severe pain in the legs, ankles, knees, etc. STOP exercising and consult your physician.
- Always use the magnetic safety key with the cord attached to yourself for the duration of your workout.
- Do not allow anyone to reach under or be near the treadmill while you are exercising.
- Never attempt to mount or dismount the treadbelt while it is still moving.
- Never allow more than one person on the treadmill at a time.
- When you are finished exercising, be sure to leave your treadmill in a non-elevated position to help prevent toys or other objects from getting trapped under your treadmill.
- Always unplug your treadmill during a electrical storm or during prolonged periods of non-use.
- Never move the treadbelt while the power is turned off.
- The heart rate timer is not a medical device. Various factors, including your ability to find and accurately count your pulse will affect the accuracy of the heart rate reading. It is intended as an aid in determining heart rate trends in general.
- Wear only the appropriate running or walking shoes and only the appropriate exercise attire while exercising.

## Installation Requirements

- Electrical Requirements: It is the owners responsibility to be sure that the electrical requirements for PaceMaster are adequate. PaceMaster requires standard household current (120 VAC/60 Hz.) and a dedicated 20 amp non-switched circuit. The treadmill has a three prong plug, this grounding plug is necessary. Attempting to bypass it with an adapter or in any way defeating it's purpose can result in a serious shock hazard. As a safety precaution you should unplug the treadmill during electrical storms or if the treadmill will not be in use for periods greater than one week.



**CAUTION:** If you need to use an extension cord it must be a 14 gauge three wire cord and no longer than 12 feet.

- Where to install your treadmill?: Your treadmill should be installed indoors on a flat level surface near a 120Volt/ 20Amp electrical outlet, preferably no more than 5 feet from the outlet to eliminate the need for an extension cord. You must have a minimum of 4 feet clearance between the rear of the treadmill and any wall or obstruction.



If you are installing your treadmill on a carpeted surface, use a pad or scrap piece of carpet in between to avoid marking or soiling of the carpet. Deep pile carpet is not recommended.

## Unpacking Your Treadmill

- The PaceMaster is packed in five pieces: the main unit, the handlebar, the siderails, the motor cover, and the hardware package which contains this manual. Once you have removed all of the pieces from the box, inspection of the treadmill should be made to check for any concealed damage that may have occurred during shipment.
- Before assembling your treadmill, open the hardware package and verify that you have the following items.

- 2 ----- 1/4 - 20 x 4" black carriage bolt
- 4 ----- 1/4-20 x 3" silver carriage bolt
- 6 ----- 1/4-20 kep nuts
- 3 ----- #8 x 1/2 black sheet metal screws
- 2 ----- black siderail brackets
- 2 ----- 1" OD fender washers
- 1 ----- 3/16" allen wrench
- 1 ----- magnetic key with garment clip



If any parts are missing please contact your authorized PaceMaster dealer.

## Tools Required for Assembly

- 3/16" allen wrench (supplied)
- 7/16 combination wrench
- Phillips head screwdriver

## Assembly Instructions



**CAUTION:** Be extremely careful not to damage the speed sensor (figure 2) while installing the handlebar or motor cover.

1. Carefully place the bottom of the handlebar on the frame so the two holes in the plate at the bottom of the handlebar line up with the two holes in the frame. Insert two 3" carriage bolts #1 through the handlebar and the frame and install two kep nuts #2 to keep the handlebar in place. Follow the same procedure for the other side of the handlebar. Do not tighten any nuts until both sides are bolted in place.

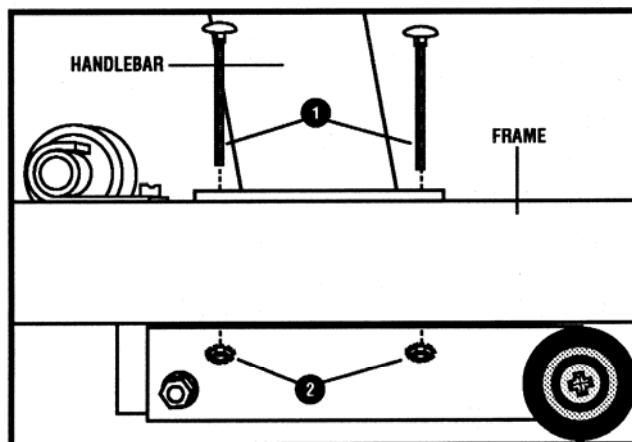
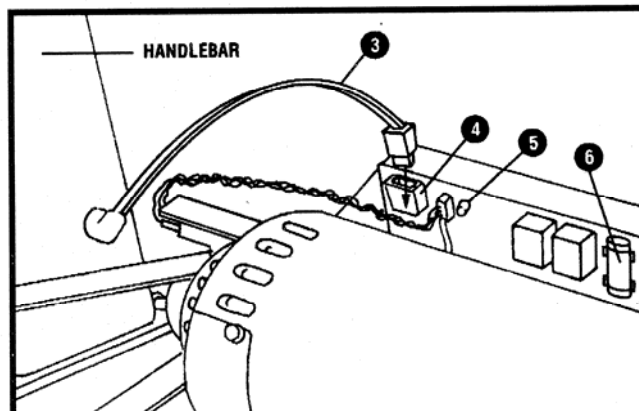



Figure 1

2. With the handlebar in place plug the wire harness #3 into the socket #4 on the power supply board (figure 2).
3. Take one of the siderails #7 (figure 3) and slide the end with the grip over the end of the steel tube protruding from the control panel. Slide the siderail on until the grip touches the control panel.



4. As shown in Figure 4 put one of the black 4" carriage bolts #8 through the siderail #7, bracket #9 (make sure the foam on the back of bracket #9 is facing up) and through the frame. When the bolt is all the way through the frame install a 1" fender washer #10 and a kep nut #2. Use this procedure to install the other siderail and then tighten both siderails.

5. Standing in front of the treadmill (as shown in figure 5) pick up the motor cover so that it is level and the word PaceMaster is upside down. Holding the motor cover level and waist high tilt it 45 degrees by lowering your left hand. Now slide it between the handlebar and rotate the motor cover so that it is level by raising your left hand. Lower the cover all the way making sure you keep it level. Install the three #8x1/2" black sheet metal screws into the front of the motor cover. Press down on each side of the motor cover where it meets the gray plastic shrouds to lock the Velcro pads in place.

 **CAUTION:** Do not raise or lower motor cover without it being level.

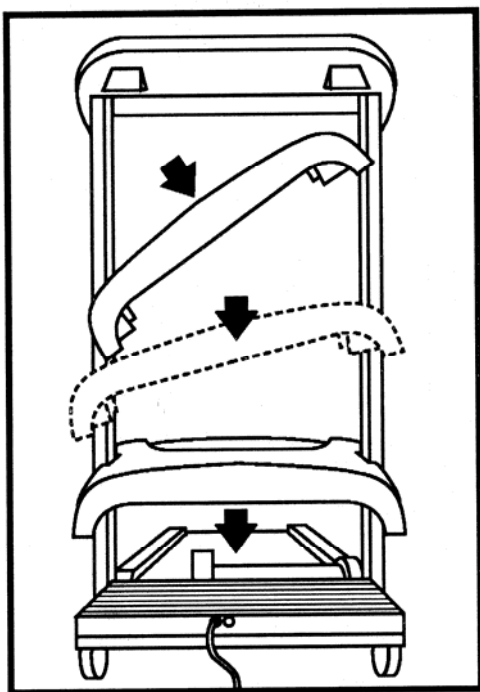

Figure 5

Figure 2

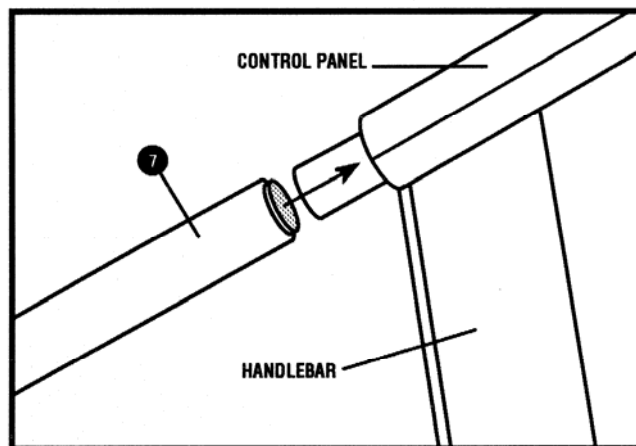

Figure 3

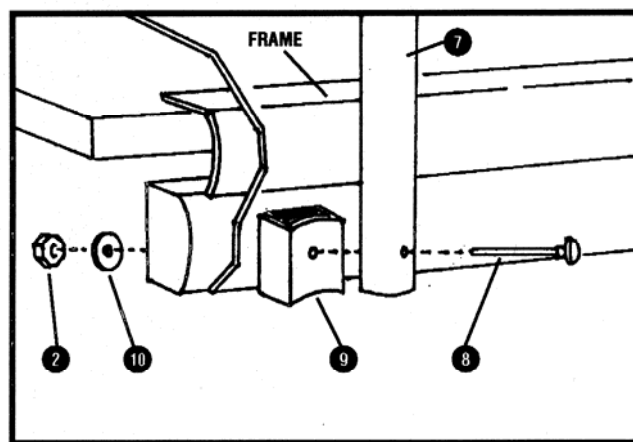



Figure 4

## Testing Your Treadmill

• Your treadmill is completely adjusted and tested at the factory. However, due to changes occurring during shipment it should be tested. Once you have assembled your treadmill and it is located where it will be used, proceed as follows (do not make any adjustments unless necessary).

 **CAUTION:** When performing these tests DO NOT stand on the treadbelt. Once tested, always start and finish on the treadbelt.

1. After your treadmill is in place and plugged in to the wall outlet, attach the garment clip (located on the end of the cord opposite the safety magnetic key) to your clothing at waist level and insert the magnetic key in to the recess on the control panel. You will see "150" in the speed window and "Lb" flashing in the distance window of the display. This is the current user weight entered, for testing this is fine (in standard operation you could change this number to represent your weight by pressing the UP or DOWN buttons).
2. Now set the workout time for 3 minutes by pressing the MIN button 3 times and set the workout speed by pressing the FASTER button until the speed displayed is 2.0 m.p.h..
3. Press the START / STOP button. After a few second delay the treadbelt will begin to move.



**NOTE:** If the treadbelt does not move, or stops after a few seconds and displays an error message, make a note of the error message and refer to the trouble shooting section.

4. After the treadmill has reached 2.0 m.p.h. (the decimal in the speed window stops flashing) and run for a few minutes, look at the treadbelt to make sure that it is centered on the bed. If the treadbelt is not centered, refer to the maintenance section for instructions on adjustment.
5. To test the elevation the treadbelt must be moving, therefore you must set a few minutes of workout time, set a workout speed (use 1.0 m.p.h.) , and press start. To check your current elevation, press either the UP or DOWN button momentarily and your current elevation will be displayed in the distance window. To change your elevation you may either press and hold the UP or DOWN button (the elevation will change in .5 percent increments) or you may repeatedly press either button obtaining a .5 percent change per press of the button. Bring the treadmill up to 3.0 percent incline and once it reaches 3.0 percent bring it down to 0.0 percent.



**CAUTION:** Always remember to leave your treadmill at 0.0 percent incline when finished exercising.

## Understanding the PaceMaster Control Panel

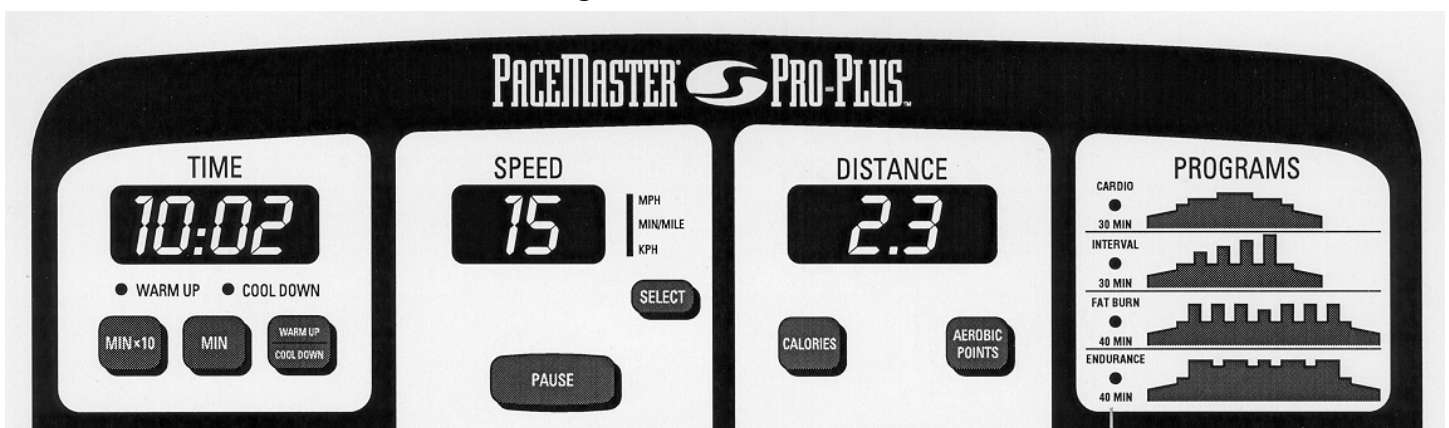

**CONTROLS** Although PaceMaster has many advanced features which allow the user complete versatility in meeting exercise needs, basic operation is extremely easy. Basic operation involves setting your TIME and SPEED goals, then pressing the START button. PaceMaster will gradually accelerate to your set speed, maintain that speed until the timer counts to zero, then gradually come to a complete stop. During your exercise the displays keep track of your time remaining, speed, distance traveled, calories burned, and aerobic points earned.

- **MAGNETIC SAFETY KEY** - The magnetic safety key with its red cord and garment clip is a safety feature of the PaceMaster. Attach the clip to your clothing at waist level (where a belt buckle would normally be positioned). To turn PaceMaster on insert the circular black key into the recess on the control panel. During exercise an emergency stop can be made at any time by pulling on the cord to release the key from its slot. This would happen automatically should a fall occur. **Using the key to stop PaceMaster is an emergency procedure only!** Normally you should stop PaceMaster by pressing the stop key or allowing the timer count to zero. Once PaceMaster has come to a complete stop remove the key to turn PaceMaster off. When not in use store the magnetic safety key in a safe place to prevent unauthorized use. Always use the magnetic safety key with the clip attached to your waist when operating the PaceMaster.
- **POWER UP** - Using the magnetic safety key as described above, place the magnet into the slot. The control panel will first display the software version of your treadmill in the time window for about 2 seconds and then "150 Lb" for a few seconds indicating that PaceMaster is set for a 150 pound user. You can change the weight to your weight by pressing the UP or DOWN buttons before the display disappears (about 3 seconds). Once you change the weight setting the new weight will appear during power up until it is changed again. You can also access the weight setting mode when ever the treadmill is not in motion by holding down the SPEED SELECT button for two seconds.
- **MINx10, MIN** - Before exercise, use these buttons to set the amount of time you wish to exercise. During exercise the TIME display will count down until zero time is left. PaceMaster will then slow to a complete stop. During exercise (except warm up or cool down periods) each press of the MIN button will increase the time remaining by one minute.
- **FASTER, SLOWER** - Before exercise, use these buttons to set your exercise speed. During exercise, these buttons allow you to adjust your speed. These buttons may also be used in programs to override speed at anytime.
- **SPEED SELECT** - Use this button to display speed in M.P.H. (miles per hour), MIN/MILE (the number of minutes it takes to complete one mile), or K.P.H. (kilometers per hour).
- **START/STOP** - After the TIME and SPEED are set, press START to begin exercise. A "beep" signals that the treadbelt will begin slowly accelerating to the selected speed. STOP may be pressed at anytime to gradually slowdown to a complete stop. Otherwise the treadbelt will stop automatically when the timer counts down to zero. A quick but safe emergency stop can be made at anytime by pulling on the safety cord to release the magnetic key from its slot. **Use this as an emergency procedure only!**
- **PAUSE** - At any time during your workout you can put your exercise "on hold" by pressing the PAUSE button. PaceMaster will stop, but retain all distance, calories, and aerobic points accumulated thus far as well as time remaining and speed. The SPEED window displays "-P-" to indicate PAUSE is active. You may then answer the phone or doorbell. To resume your workout where you left off press START.
- **UP, DOWN** - These buttons adjust user body weight. See POWER UP for details. The UP and DOWN buttons set the desired elevation (incline). Elevation is adjustable from 0% incline to 15% in 0.5% increments. To display the current elevation setting, momentarily press either the UP or DOWN button. An "E" will appear in the DISTANCE window followed by the elevation setting. For example a 3.5% incline is displayed as "E 3.5". To change elevation settings either repetitively press or hold down the appropriate button. Before exercise, set your desired elevation value. PaceMaster will not elevate to this setting until START is pressed to begin exercise. During exercise PaceMaster will immediately seek any new

elevation value set with the UP or DOWN buttons. After exercise ("End" is displayed) return PaceMaster to 0% incline by pressing the DOWN button until the elevation mechanism stops moving.

- **CALORIES** - Before exercise, you can predict the calorie burn for your workout. Enter your time, speed, and elevation goals. Press CALORIES to display your predicted calorie burn, displayed in the DISTANCE window, preceded by the letter "c". For example 143 calories is displayed as "c 143". You may fine tune your calorie burn to a specific value by changing your time, speed, or elevation. If you begin "fine tuning" within three seconds of pressing the calorie button, the calorie display will remain until "fine tuning" has stopped for three or more seconds. During exercise, press the CALORIE button to display the actual amount of calories burned thus far. The calorie display disappears three seconds after the button is pressed. If you want to have the calories continuously displayed during exercise as opposed to distance hold down the calorie button until a decimal point appears directly after the letter "c" in the calorie display. You can unlock the calorie display by pressing either the calorie or aerobic points button.

- **AEROBIC POINTS** - Functions the same as calories but displays Aerobic Points preceded by the letter "P". See "Exercise and Your Treadmill" for a description of Aerobic Points.

- **WARM UP/COOL DOWN** - Before exercise, this button can add a 5 minute warm up program prior to your main exercise routine, and/or a 5 minute cool down program following your main routine. The warm up program is designed to loosen you up and get you ready for the main exercise routine. The cool down program allows your body to gently adjust to the end of a workout instead of abruptly stopping. Most authorities advise this method of exercising.

Warm up and cool down speeds are calculated by the computer, based on your main exercise starting and finishing speeds respectively. If your main exercise starting speed is 4.5 mph or less your warm up will begin at 65% of that speed and go to 90% of that speed during the 5 minute warm up. If your main exercise finishing speed is 4.5 mph or less your cool down will begin at 90% of that speed and go to 65% of that speed during the 5 minute cool down. If your main exercise starting speed is 4.6 mph or greater your warm up will begin at 50% of that speed and go to 75% of that speed during the 5 minute warm up. If your main exercise finishing speed is 4.6 mph or greater your cool down will begin at 75% of that speed and go to 50% of that speed during the 5 minute cool down.

#### **Before Exercise:**

To add both a warm up & cool down to your workout press the warm up/cool down button once. You will see that both the warm up & cool down lights are on indicating that they will be added to your workout. You will also notice that the workout time has been increased by 10 minutes to include the warm up & cool down.

To add a warm up to your workout press the warm up/cool down button twice. You will see that the warm up light is on indicating that it will be added to your workout. You will also notice that the workout time has been increased by 5 minutes to include the warm up.

To add a cool down to your workout press the warm up/cool down button three times. You will see that the cool down light is on indicating that it will be added to your workout. You will also notice that the workout time has been increased by 5 minutes to include the cool down.

At any time during warm up, the WARM UP button can be pressed to discontinue warm up and begin your main exercise. Similarly, during main exercise you can press the COOL DOWN button to end the exercise and immediately begin a cool down.

- **PROGRAM SELECT, LEARN** - These two buttons allow PaceMaster to memorize your favorite routines and automatically repeat them at any desired time. This eliminates the need to enter time, speed, and elevation settings each time you exercise. It also eliminates the need manually change speed or elevation during your workout. Once PaceMaster LEARNS a routine, it can recall that routine and repeat it exactly, by pressing a single button!

PaceMaster is shipped from the factory with the 4 custom memories empty. For a full description of the preprogrammed courses see the section called "Using the Preprogrammed Courses". Step by step instructions for programming your own courses can be found the section "Designing Your Own Courses".

- **PROGRAM SELECT** - This button is used before your workout. After inserting the magnetic safety key and entering weight, press PROGRAM SELECT once, to retrieve the first of four factory programs stored in PaceMaster's memory. The light next to the program lights up to indicate you have chosen that program. Notice that time, speed, and elevation settings are now displayed in the windows. Pressing PROGRAM SELECT a second time recalls the next program pressing a third time recalls "3", the fourth press recalls "4", etc.... To use one of the programs, press PROGRAM SELECT until the indicator light next to the program is on, then press START.

- **LEARN** - The LEARN button allows PaceMaster to memorize your exercise routine while you are doing it. Your program is stored in one of the four custom memories previously described, replacing the old program in that memory. To use LEARN, first use PROGRAM SELECT to select the custom memory (1,2,3, or 4) where your program will be stored. Next press the LEARN button. The light in the upper right-hand side of learn the button lights to show that you have entered the learn mode. The time and speed displays will have dashes in them indicating the old program has



been erased. Now enter your time, speed, and elevation just as you would in manual operation. Add a warm up and cool down if desired, and press START to begin exercising. Perform your exercise exactly the way you wish it to be memorized. As you are exercising, you will notice that each time you change speed or elevation the CUSTOM LEARN light flashes for a few seconds to confirm that the changes are being learned. When you have finished exercising, in other words the time has counted down to zero or you pressed STOP to shorten your exercise, "End" will appear in the SPEED window, and the total time of your memorized routine will be shown in the TIME window.

## Exercise and Your Treadmill

 **CAUTION:** Before starting any exercise program, contact your personal physician and have a complete physical. Only your physician can recommend a heart rate training zone that is suitable for you. The following information is provided as a general guideline and should be used as such. You must modify these guidelines to suit your own personal fitness level.

Aerobic, by definition, means in the presence of oxygen. Aerobic exercise refers to a physical activity which requires large amounts of oxygen for long periods of time. Building strength, muscle tone, and burning fat are benefits of aerobic exercise. While exercising, your muscles require large of oxygen, and it is your lungs that must oxygenate the blood that your heart will pump to the muscles. Therefore, aerobic exercise is not only working your muscles, but strengthening your cardiovascular system as well.

Aerobic points measure the effectiveness of your exercise on your cardiovascular system. Dr. Kenneth Cooper formulated the aerobic point system to allow an individual to determine how much their workout benefits their cardiovascular system. According to Dr. Cooper's system, an adult male requires 32 aerobic points of activity weekly to maintain a minimum cardiovascular fitness level. An adult female requires 28 aerobic points of activity weekly. These are not starting goals. These are goals that should gradually be worked up to.

### How strenuous should my exercise be?

You can determine how strenuous to make your exercise by monitoring your heart rate. Your maximum heart rate is the fastest that your heart can beat, and is usually determined by subtracting your age from 220. For example if you are 40 years old your maximum heart rate is 220 - 40 or 180 beats per minute. Exercising with a heart rate greater than 75% of your maximum heart rate may be too strenuous unless you are in excellent physical condition. Exercising at a heart rate less than 50% of your maximum gives your heart and lungs little conditioning. Therefore, it is most beneficial to exercise with your heart rate between 50% and 75% of maximum. This 50 - 75% range is called your target heart rate zone.

Upon beginning an exercise program, keep your heart rate closer to the low end of your training zone (50%). As your fitness level increases, work up to the higher end of your target zone (75%). Following at least six months of regular exercise some people choose to exercise at rates of up to 85%. It is not necessary to work that hard to maintain good cardiovascular condition.

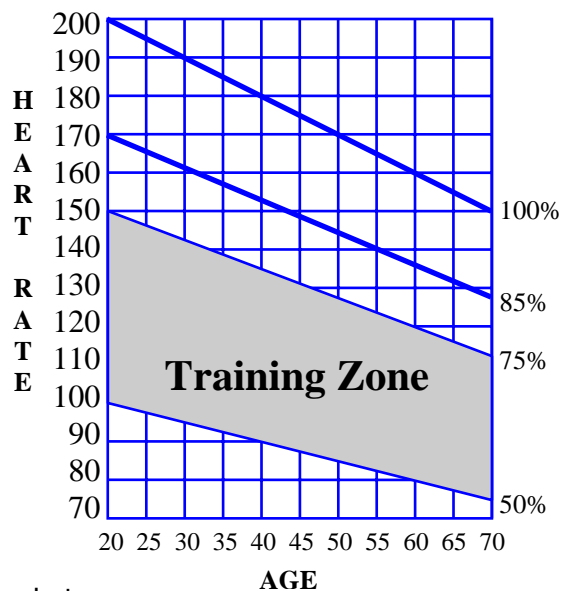

 **CAUTION:** High blood pressure medicines can lower your maximum heart rate and therefore lower your training zone. If this applies to you, consult your doctor.

### • How long should I exercise?

There are three equally important parts to a workout: a warm up, a main exercise routine, and a cool down.

- A warm up should be 5 minutes in duration starting at a lower pace, and gradually increasing, until the beginning of the main exercise routine.
- The main routine is the part of your workout during which you maintain your heart rate in the training zone. The goal for this segment is 30 - 60 minutes in duration. Initially the time should be less than 30 minutes, but as your fitness level increases, the time in the training zone can increase, depending on how briskly you walk or run. You should gradually work up to the 30 - 60 minute goal.
- Following your main routine it is important to slow down gradually. This allows your body to relax at a safe rate. Abrupt stopping can cause dizziness and other non-beneficial effects.

We, at Aerobics Inc., realize the importance of a warm up and cool down. Therefore you may add an automatic 5 minute warm up and cool down to your workout by simply pressing the warm up/cool down button on the control panel prior to beginning your workout.

- **How often should I exercise?**

Exercise 3 or 4 times per week to achieve and then maintain your desired fitness level. Exercising less than 3 or 4 times per week, decreases the benefits and slows progress. An every other day schedule works best.

- **Is there a limit to the benefits of exercising?**

That depends on the benefits you are aiming to achieve. Anything more than 30 minutes daily of very vigorous exercise, or 60 minutes daily of moderately vigorous exercise, results in little added conditioning of your heart and lungs. If your goal is weight loss or weight control, more exercise burns more calories. But like everything else in life, exercise can be over done. Too much exercise can have detrimental effects. Also keep in mind, effective weight control requires adjusting your caloric intake in addition to regular exercise.

## Using PaceMaster for the First Time

Before starting any exercise program, contact your personal physician and have a complete physical. Only your physician can recommend a heart rate training zone that is suitable for you.

 **CAUTION:** Before using your treadmill make sure that all children, pets, and other objects are at least three feet away from the treadmill in all directions during the entire time the treadmill is in operation.

1. Stand on the center of the treadbelt. Attach the clip of the magnetic safety key to your clothing at waist level. Insert the circular magnetic into the recess on the control panel keyboard.
2. After the machine powers up, the previous weight setting is displayed in the SPEED window and "Lb" flashes in the DISTANCE window. Adjust this number to represent your weight using the UP and DOWN buttons. Once adjusted, the weight display will disappear in a few seconds, indicating that it has been memorized. Entering weight has no effect on PaceMaster's performance, it is only used to more accurately calculate calories burned.
3. Set the desired workout time using the MINx10 or MIN buttons.
4. Set the desired workout speed using the FASTER and SLOWER buttons. For first time users we recommend a starting speed of 2.0 m.p.h. until comfortable walking on PaceMaster, at which time the speed may be increased.
5. Keeping one hand on the siderail while standing on the treadbelt, press START. After a few second delay the treadbelt will gradually accelerate to the set speed (when the decimal in the speed window stops flashing you have reached the set speed). Initially keep both hands on the siderails until comfortable walking on your treadmill. Once comfortable, try removing your hands to let them swing naturally, as you would walking outdoors. Always hold on to the siderails or handle bar with one hand when operating the buttons of the control panel.
6. Now that you are walking, speed and/or elevation may be varied as often as desired during your workout.
7. When the timer counts down to zero, the treadbelt gradually slows to a stop.
8. STOP may be pressed at any time during your workout to gradually stop.
9. If a problem occurs, PaceMaster can be stopped quickly by pulling on the red safety cord to remove the magnetic key from the control panel. The treadmill will stop more abruptly, but still gently enough to prevent you from being thrown. **This is an emergency procedure only and should not be used as the normal stopping procedure.**

## Using The Preprogrammed Courses

This section describes how to use the preprogrammed courses or any course you might program in the memory of your PaceMaster.

1. Stand on the center of the treadbelt. Attach the clip of the magnetic safety key to your clothing at waist level. Insert the circular magnetic into the recess on the control panel keyboard.
2. Enter your weight at the flashing "Lb" prompt using the UP or DOWN buttons.
3. Press the PROGRAM SELECT button until the light to the left of the program you desire is lit.
4. Press START to begin your workout.

5. During the workout the computer will notify you of any speed or elevation changes in the program by flashing the current speed and/or elevation a few times, then displaying the new speed or elevation.
- At anytime during the workout you may increase or decrease your speed or elevation to meet your own fitness level, but at the next point in time when there is a speed or elevation change, the treadmill will go to its new values. You may choose to override these new values at any time.
  - If there is a warm up/cool down as part of the program chosen, you may shorten the warm up by pressing the WARM UP button prior to its completion. This will advance you to the beginning of the main exercise routine. You may also choose to begin your cool down prior to the end of your main exercise routine. This is done by pressing the COOL DOWN button before time has elapsed on the main routine, this will put you at the beginning of the cool down routine.
  - During the main routine you may, if desired, lengthen the workout by pressing the MIN button, which will add 1 minute to the main routine each time you press it.

### Program #1 Cardiovascular - 30 minutes

Speed Profile

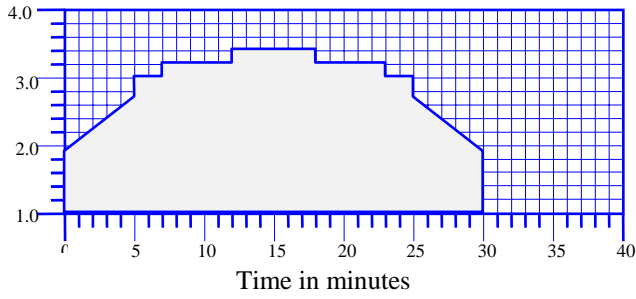

Elevation Profile

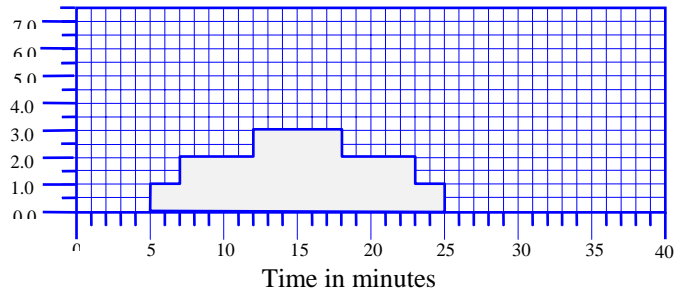

### Program #2 Interval - 30 minutes

Speed Profile

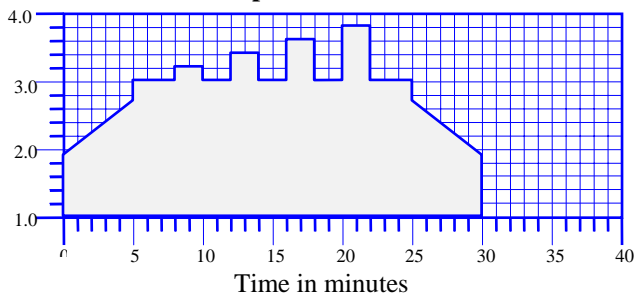

Elevation Profile

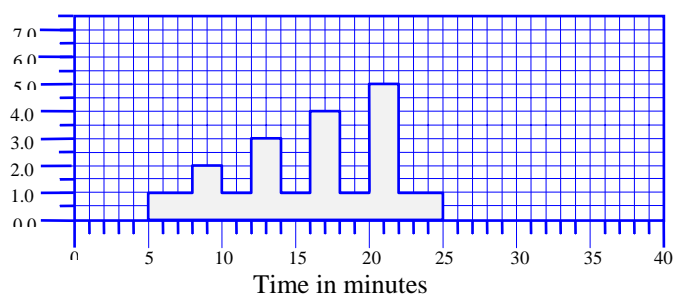

### Program #3 Fat Burn - 40 minutes

Speed Profile

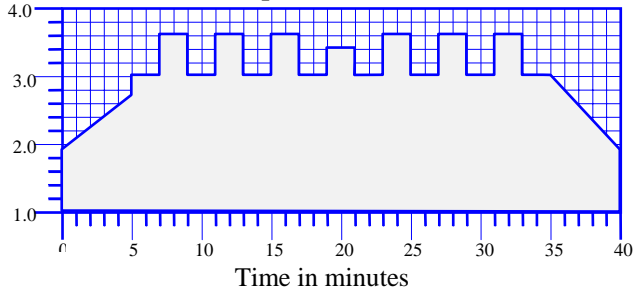

Elevation Profile

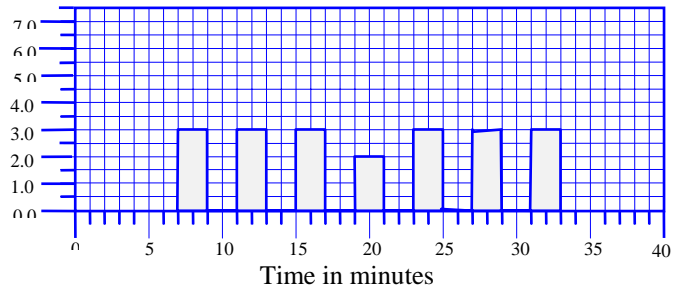

### Program #4 Endurance - 40 minutes

Speed Profile

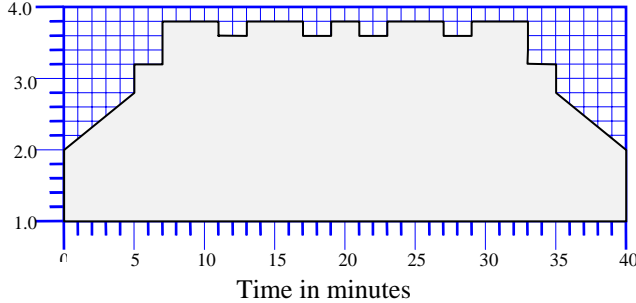

Elevation Profile

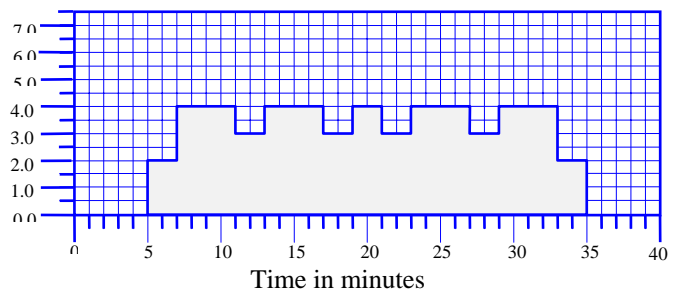

## Designing Your Own Courses

Designing your own workout course allows you to tailor the workout to your specific fitness level, abilities, and goals. PaceMaster has the ability to remember four of your favorite exercise routines. One routine can be stored in each of the four custom memory positions. Be certain that the proper custom memory (1,2,3, or 4) has been selected. Realize that you will no longer be able to use the existing program in that memory position once a new one is memorized.

1. Stand on the center of the treadmill. Attach the clip of the magnetic safety key to your clothing at waist level. Insert the circular magnetic into the recess on the control panel keyboard.
2. Enter your weight at the flashing "Lb" prompt using the UP or DOWN buttons.
3. Press PROGRAM SELECT to select the memory position where the new program will be stored (Custom 1,2,3 or 4)
4. If the light in the LEARN button is on go to step 5. If the light in the LEARN button is not on, press the LEARN button, this erases the program currently stored in this memory and allows you to store a new one.
5. Set the desired workout time, starting speed, warm up/cool down (if desired), and starting elevation.
6. Press START to begin your workout. Do your exercise exactly as you wish it to be memorized.
7. During the workout, speed and elevation changes can be made as often as desired. The computer will remember all of the changes made. You're allowed to make between 28 and 50 speed and elevation changes per course. If the maximum number of changes are exceeded the LEARN light will turn off and any further changes will not be memorized.
8. When the workout is ended, by either pressing stop, or letting the time expire, the course is automatically stored in memory.



During your main routine you may, if desired, lengthen your workout by pressing the MIN button, which will add 1 minute to your main routine each time you press it.

## Maintenance



**CAUTION:** Be sure to unplug your treadmill before attempting any cleaning or maintenance.

The following section describes necessary maintenance for the PaceMaster treadmill. This maintenance is the responsibility of the consumer and is not covered under our warranty. Failure to perform this necessary maintenance could result in damage to your treadmill.

### Bed and belt cleaning

The treadmill on your PaceMaster rides on a low friction bed. Proper operation will be jeopardized if any water, dirt, solvents, fluids, or abrasive materials are permitted to become between the treadmill and the bed. For this reason extra care must be used in keeping the treadmill clean. Use a soft, damp cloth wipe the belt and the area between the belt and the side of the machine.

### Lubrication

All of the bearings in the PaceMaster treadmill are sealed for maintenance free operation, and require no lubrication. The treadmill bed and treadmill are lubricated at the factory and also maintenance free. Any attempt to lubricate underneath the treadmill will result in damage, especially if silicone or any other lubricant is used.

The siderails are made of steel. By applying a coat of automotive wax to them once in a while, you will help prevent them from rusting.

## Centering Your Treadbelt

To improve treadbelt life, the treadbelt should remain reasonably centered while in use. To center the treadbelt, first walk on the belt at 2.5 m.p.h. for a few minutes. Determine whether the belt drifts too far to the left or right side. If adjustment is required, stop the treadmill and follow the steps listed below. Never make any adjustments while the treadbelt is moving.

 **CAUTION:** The power must be turned off before making adjustments.

Use a 3/16" allen wrench for the following adjustments

1. If the belt is drifting to the left, turn the left-hand adjustment bolt #13 1/4 turn clockwise and the right-hand adjustment bolt #13 1/4 turn counter-clockwise.
2. If the belt is drifting to the right, turn the right-hand adjustment bolt #13 1/4 turn clockwise and the left-hand adjustment bolt #13 1/4 turn counterclockwise.
3. Walk on the treadbelt for 1 minute and observe, if the belt is not yet centered, repeat the last step.

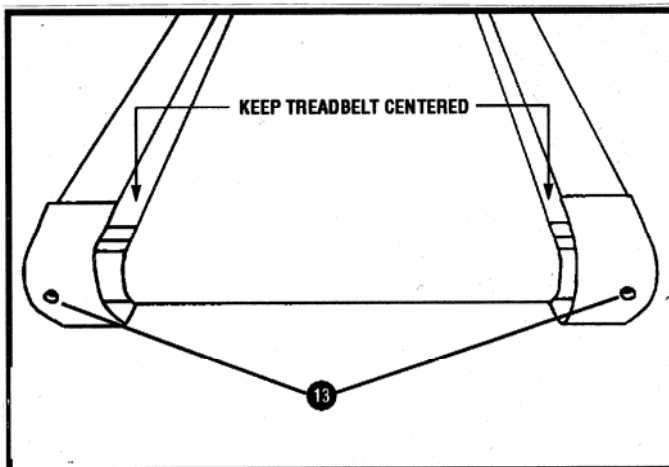

## Hesitation of the Treadbelt

Hesitation of the treadbelt usually indicates slippage of either the treadbelt (the belt you walk on) or the drive belt (the belt connecting the drive roller to the motor). To determine which of these belts is slipping, first adjust the drive belt tension and test to see if the slippage stops. If the hesitation is not corrected then the treadbelt tension needs adjustment.

 **CAUTION:** The power must be turned off before making adjustments.

### Drive belt tension adjustment

1. Use a phillips head screwdriver to remove the 3 screws that hold the front of the motor cover in place.
2. Locate the four motor mount screws #12 as shown in the diagram and loosen them each two turns each using the 3/16" allen wrench.
3. Locate the drive belt adjustment screw #14 in the lower front end of the treadmill. Insert the allen wrench into the drive belt adjustment screw. Turn the screw 1/2 turn clockwise.
4. Complete the adjustment by tightening the four motor mount screws.
5. Walk on the treadmill to determine if the slippage is decreased or eliminated.
6. If no improvement is observed, the hesitation may be caused by a loose treadbelt - see "Treadbelt tension adjustment" below. If improvement is noticed but slippage is still present, repeat the procedure and test again. If you tighten the drive belt adjustment screw 1 1/2 turns and there is still hesitation (slippage) contact your authorized PaceMaster dealer. Tightening the drive belt adjustment screw more than 1 1/2 turns can result in bearing damage to the motor and/or drive roller.

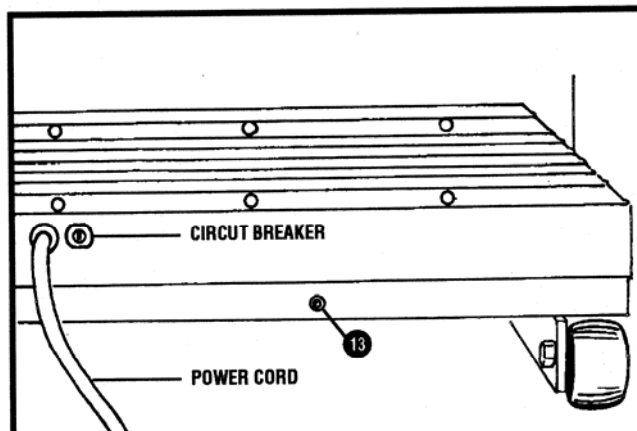
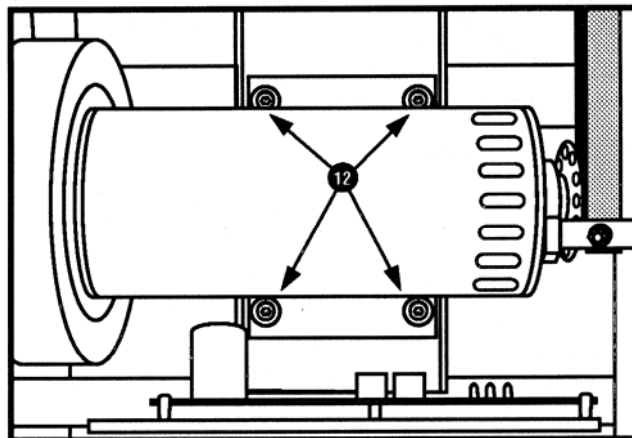

### Treadbelt tension adjustment

1. Locate the two treadbelt adjustment screws "13" as shown.

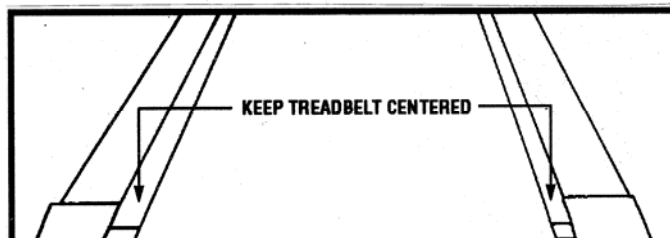

2. Turn both the left and right treadbelt adjustment screws 1/2 turn clockwise.
3. Walk on the treadmill to see if the adjustment you made decreased the slippage.
4. If a significant decrease in slippage was observed, go to step 2. If you tighten the treadbelt 1 1/2 turns per side and slippage is still present, do not continue to adjust the treadbelt tension. Contact your authorized PaceMaster dealer.

Figure 9

## Troubleshooting

Problem	Cause	Solution
No power	Unit is not plugged in	Plug unit in.
	Magnetic key is not in place	Insert the magnetic key.
	Household circuit breaker is off	Reset the circuit breaker.
	Treadmill circuit breaker has been tripped	Reset treadmill circuit breaker (located next to power cord on front of treadmill see figure 8, page 14).

If at any point prior to, during, or after your workout the treadmill does not function properly and displays an error message, make a note of the error message and the conditions under which it occurred (i.e. speed, elevation, etc..). First you should run the treadmill again to see if the error message occurs again under the same conditions. If it occurs again call the dealer where you purchased the treadmill and explain the problem so he can arrange to service your treadmill.

## Interference

1. Reorient or relocate the antenna for the device that is receiving the interference.
2. Increase the distance between the device and the treadmill.
3. Confirm that the device is not plugged into an outlet on the same circuit as the treadmill.

## Specifications

Motor - 2.5 HP continuous duty DC @ 120 VAC/60 Hz., 18.8 Amps DC

Speed Range - .7 to 11.0 M.P.H. (.1 M.P.H. increments)

Elevation Range - 0 to 15% grade (.5% increments)

Operating Temperature Range - 50° to 100° F

Maximum Permitted Weight - 300 lbs.

© Aerobics, Inc. 1995

PaceMaster is a registered trademark of Aerobics Inc.

Workout Log

This page should be **photocopied** and used to keep a daily record of your workouts. By recording your workouts on a copy of this page you will be able to keep track of your progress and this is also good for

